

# Transfer Switch Diagram (Typical)

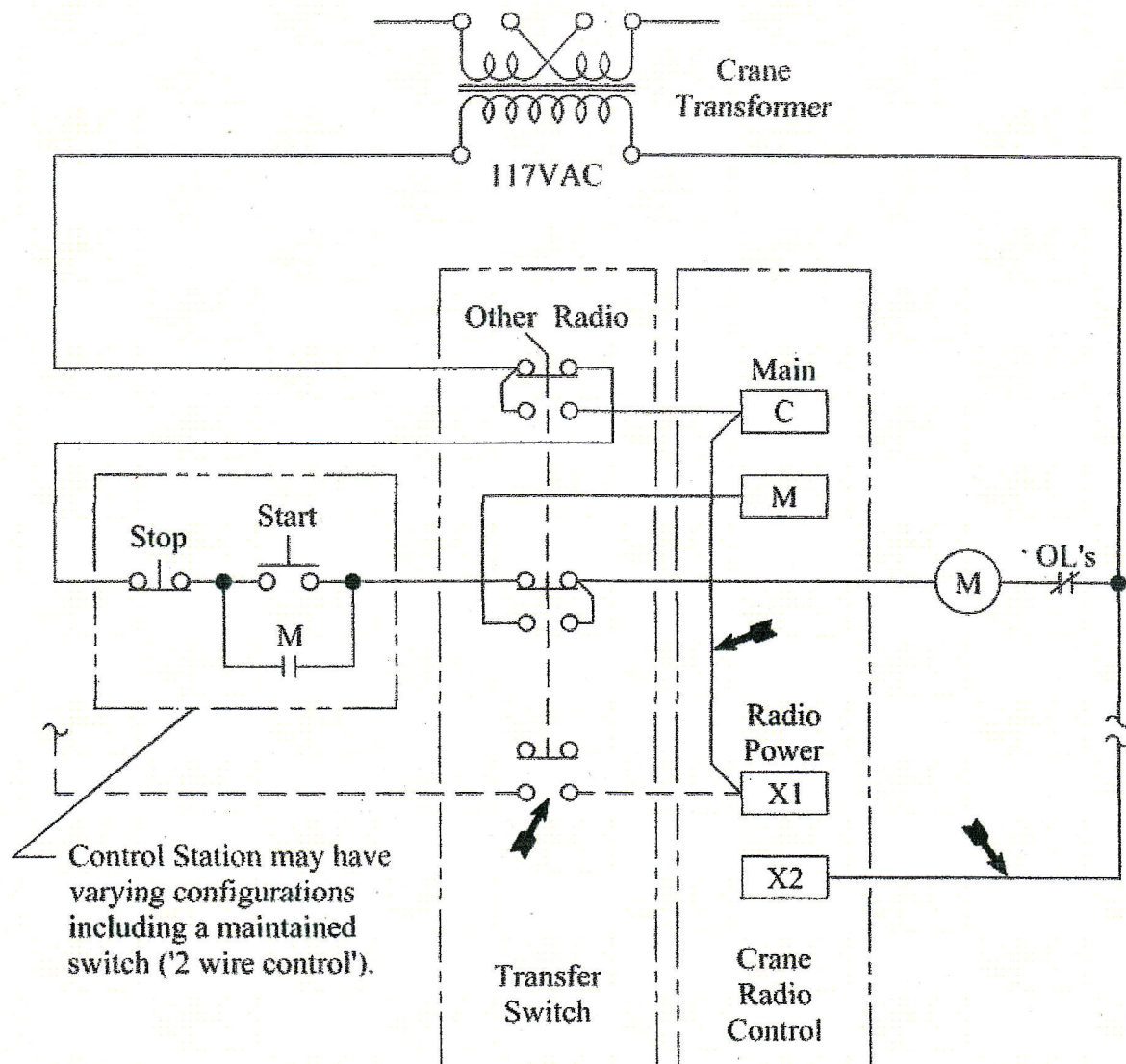

➔ If Radio Power is to be separate from Main Power, omit jumper from C (Main) to X1 and add Transfer Switch contact with dashed line connection as shown. X1 and X2 must be connected to the same 110-120VAC Control Transformers' Secondary.

NOTE: This diagram is an example only. Equipment control circuits may vary greatly. Control connections should be carefully considered to provide proper operation and avoid feedback circuits.

FIG. 4-1:  
TYPICAL TRANSFER SWITCH & MAIN LINE CONTACTOR CIRCUIT